

# G.129 4<sup>th</sup> Axis Automatic Orthogonal heads

## Main features

Wesentliche Merkmale

### Alternative outputs

Andere Werkzeugaufnahme HSK / Capto / Big Plus

### Automatic positioning by machine spindle

Automatische Positionierung durch die Maschinenspindel

### Positioning every 2.5° with Hirth crown

Positionierung all 2.5° mit Hirth Kupplung ±95°

### Hydraulic tool clamping

Hydraulischer Werkzeugwechsel

### Cooled bearings

Gekühlte Lager





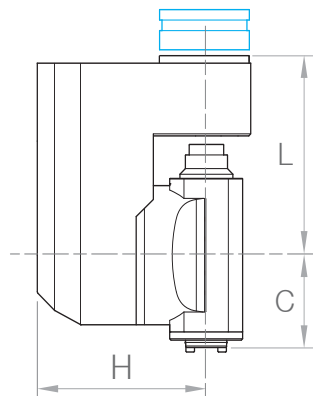

### Optional coolant through / air blow

Optional Innenkühlung / Sperrluft

### Flange to any machine

Adaption für jede Art von Maschine



Code		 kW	 Nm. Max.	 RPM. Max.		 KG	L mm	C mm	H mm
G.129.30	ISO-50	30	700	4.000	1:1	700	500	260	500
G.129.50	ISO-50	50	2.000	3.000	1:1	800	500	300	600

Other measures on request Andere Maße auf Anfrage