

G.185

Flat surface
Grinding heads



Main features

Wesentliche Merkmale

Belt transmission / Speed adjustment

Riemenantrieb / DrehzahlEinstellung

Powered by electric motor

Von einem Elektromotor angetrieben

Optional balancing and vibration control

Optionale Auswucht und Vibrationskontrolle

Flange to any machine

Adaption für jede Art von Maschine

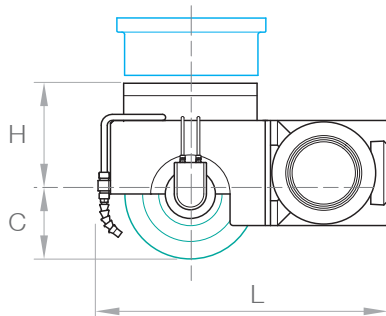

Other measures on request / Andere Maße auf Anfrage

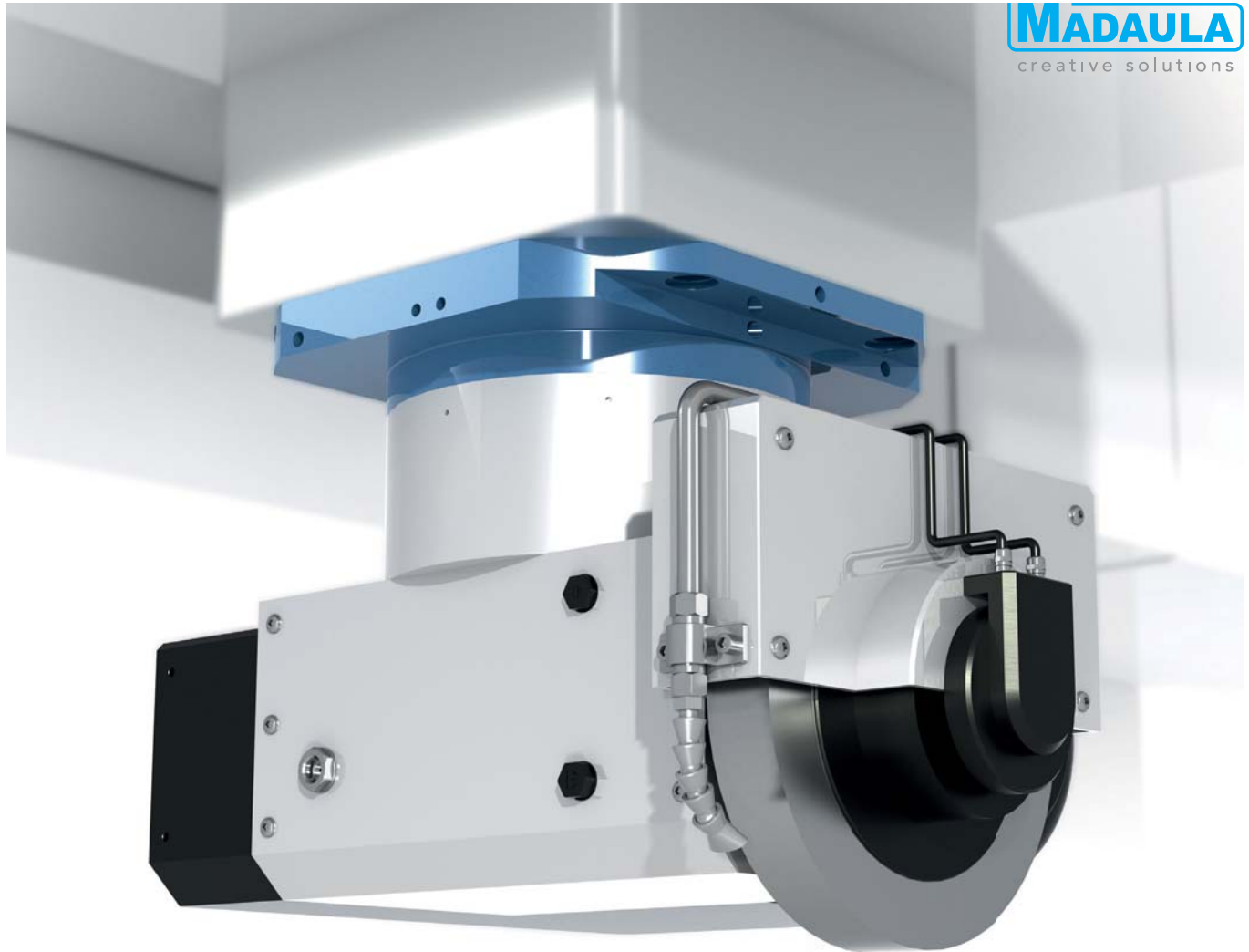

MADAULA
creative solutions

Code



kW

Nm. Max.

RPM. Max.

Grinding wheel ØD
mm

G.185.100

HSK-100 or shaft

11

72

1.500

Max. 500